

# OWNERS MANUAL

## INSTALLATION AND OPERATING INSTRUCTIONS

U.S. Patent 5,133,639

### 4" SUBMERSIBLE PUMPS

Two and Three Wire

Single and Three Phase

1/2 through 10 H.P.

60 Hz

Record the following information from the motor and pump nameplates for future reference:

Pump Model No. \_\_\_\_\_

Pump Serial No. \_\_\_\_\_

Motor Model No. \_\_\_\_\_

Motor Serial No. \_\_\_\_\_

H.P. Volts/Hz/Ph \_\_\_\_\_

Rated Amp Draw \_\_\_\_\_

Carefully read and follow all safety instructions in this manual or on pump.

**⚠ This is the safety-alert.** When you see this symbol on your pump or in this manual, look for one of the following signal words and be alert to the potential for personal injury.

**⚠ DANGER** warns about hazards that **will** cause serious personal injury, death or major property damage if ignored.

**⚠ WARNING** warns about hazards that **can** cause serious personal injury, death or major property damage if ignored.

**⚠ CAUTION** warns about hazards that **will** or **can** cause minor personal injury or property damage if ignored.

The word **NOTICE** indicates special instructions which are important but not related to hazards.

To avoid serious or fatal personal injury and possible property damage, carefully read and follow the safety instructions.

1. **⚠ WARNING** Hazardous pressure. Under certain conditions, submersible pumps can develop extremely high pressure. Install a pressure relief valve capable of passing entire pump flow at 75 PSI (517 kPa) when using an air over water pressure tank. Install a pressure relief valve capable of passing entire pump flow at 100 PSI (690 kPa) when using a pre-charged pressure tank.

**⚠** Do not allow pump, pressure tank, piping, or any other system component containing water to freeze. Freezing may damage system, leading to injury or flooding. Allowing pump or system components to freeze will void warranty.

2. **⚠ WARNING** Hazardous voltage. Can shock, burn or cause death. To avoid dangerous or fatal electric shock hazard, use pump only in a water well.

**⚠ WARNING** Risk of dangerous or fatal electrical shock. Do not install this pump in any pond, river, or other open body of water that could be used for swimming or recreation. Do not swim, wade or play in a body of water in which a submersible pump has been installed.

**⚠** Installation must meet United States National Electrical Code, Canadian Electrical Code, and local codes (as applicable) for all wiring.

**⚠** Disconnect electrical power supply before installing or servicing pump.

**⚠** Make sure line voltage and frequency of power supply match motor nameplate voltage and frequency.

3. Install pump according to all plumbing, pump and well code requirements.
4. Test well water for purity before using well. Call

your local health department for testing procedure.

5. During installation, keep well covered as much as possible to prevent leaves and foreign matter from falling into well. Foreign objects in well can contaminate the water and cause serious mechanical damage to the pump.
6. Pipe joint compound can cause cracking in plastics. Use only teflon tape when sealing joints in plastic pipe or connecting pipe to thermoplastic pumps.

## TABLE OF CONTENTS

Safety Instructions	2
Pre-Installation	2
Electrical	2-18
PENTEK XE-Series	4
PENTEK T-Series	5-6
PENTEK 3-Phase	7
Franklin	8-11
Wiring	12-18
Installation	19-20
Initial Startup	20-21
Effluent Applications	21
Connecting to Tank/Water System	21-23
Troubleshooting Guide	24-25
Warranty	26

## PRE-INSTALLATION

Inspect pump and motor for delivery damage. Report any damage immediately to the shipping carrier or to your dealer.

The well driller should thoroughly develop the well (that is, pump out all fine sand and foreign matter) before pump is installed.

Pump performance is based on pumping clear, cold, liquid water.

Warranty is void in the following conditions:

- If pump has pumped excessive sand – excessive sand can cause premature wear to pump.
- If water is corrosive.
- If entrained gas or air are present in the water being pumped – these can reduce flow and cause cavitation which can damage pump.
- If pump has been operated with discharge valve closed – severe internal damage will result.

Install pump at least 15 to 20' (4.5 to 6M) below the lowest water level reached with pump running (lowest draw-down water level), and at least 5' (1.5M) above the bottom of the well.

## WIRING/GROUNDING:

**⚠ WARNING** Hazardous voltage. Can shock, burn, or cause death. Permanently ground pump, motor and control box before connecting power supply to motor.

Ground pump and motor in accordance with the local codes and ordinances. Use a copper ground wire at least as large as wires carrying current to motor.

Motor is supplied with a copper ground wire. Splice this ground wire to a copper conductor that matches motor wire size specified in cable sizing charts, pages 5, 6, 10, and 11. See Pages 19 and 20 for cable splicing instructions. Permanently ground pump, motor and control box before connecting power cable to power supply. Connect ground wire to approved ground first and then connect to equipment being installed.

**Do not ground to a gas supply line.**

**▲WARNING** Fire and electrical shock hazard. If using a drop cable larger than No. 10 (5.5mm<sup>2</sup>) (for example, No. 8 (8.4mm<sup>2</sup>) wire) between pump and control box, run cable to a separate junction box. Connect junction box to control box with a No. 10 (5.5mm<sup>2</sup>) or smaller wire (depending on amp rating of pump – see Table II, III, or IV).

**For more information, contact your local code officials.**

#### **WIRING CONNECTIONS:**

Installation must meet United States National Electrical Code, Canadian Electrical Code and local codes for all wiring (as applicable).

Use only copper wire when making connections to pump and control box.

To avoid over-heating wire and excessive voltage drop at motor, be sure that wire size is at least as large as size listed in cable sizing charts for your horsepower pump and length of wire run.

**NOTICE:** See Pages 14 through 18 for typical wiring hookups and control box identification.

**NOTICE:** When built-in overheating protection is not provided, install an approved overload equipped motor control that matches motor input in full load amps. Select or adjust overload element(s) in accordance with control instructions. When built-in overheating protection is provided, use an approved motor control that matches motor input in full load amperes.

#### **Rotation – (3 Phase only)**

To make sure motor is running in the right direction, proceed carefully as follows:

After electrical connections have been made as outlined, and with pump hanging in well supported from clamp on the discharge pipe, turn on then turn off the switch connecting the motor to the power supply line. Note rotation of pump as motor starts. If connections are properly made, pump will “jerk” clockwise when looking into the pump discharge when started. If “jerk” is counter-clockwise, the motor is running in the

wrong direction. Interchange any two cable leads where they connect to the “lead” terminals in the magnetic starter. With connections properly made, and pump lowered into water, turn on the switch again and the pump should deliver water according to the performance charts.

#### **OVERLOAD PROTECTION OF THREE PHASE SUBMERSIBLE MOTORS – CLASS 10 PROTECTION REQUIRED**

The characteristics of submersible motors are different from standard motors and special overload protection is required.

If the motor is stalled, the overload must trip within 10 seconds to protect the motor windings. The installer must use SUBTROL or the quick-trip protection shown in Tables VIII and IX. All recommended overload selections are of the ambient compensated type to maintain protection at high and low air temperatures.

All heaters and amp settings shown are based on total line amps. When a six-lead motor is used with a Wye-Delta starter, divide motor amps by 1.732 to make your selection or adjustment for heaters carrying phase amps.

Table VIII lists the correct selection and settings of overloads for PENTEK T-Series motors. Table IX lists the same for Franklin motors. Approval of other types may be requested from the motor manufacturer.

**NOTICE:** Warranty on three phase submersible motors is void unless proper quick trip protection in all three motor lines is used.

#### **SURGE ARRESTERS IN CONTROL BOX**

**Grounding: When the box has a surge arrester, the surge arrester MUST be grounded, metal to metal, all the way to the water strata for the arrester to be effective. Grounding the arrester to a driven ground rod provides little or no protection for the motor.**

**NOTICE:** Surge arresters DO NOT protect against direct lightning strikes.

Install grounded surge arresters to protect pump from high voltage surges. Install arrester on the incoming power line to control box or pressure switch, as close to pump motor as possible. See Figures 1 and 2 for installation wiring diagrams for arresters.

**NOTICE:** Ground the arrester with a No. 10 or larger bare wire. Ground according to local code requirements.

**NOTICE:** If surge arresters wired into the control box are against local electrical code, contact power company for correct wiring information.

**PENTEK XE-Series Motor, Submersible Motor Control, and Fusing/Wiring Specifications.**

**TABLE I: Recommended Fusing Data -  
PENTEK XE-Series 60 Hz., Single Phase, 3 Wire  
Induction Run Submersible Pump Motors**

HP	Volts/ Hz/Ph	Motor Winding Resistance-Ohms R to Y	B to Y	Service Factor Amps	Locked Rotor Amps	Fuze Size Standard/ Dual Element
1/2	115/60/1	5.7-7.0	1.1-1.4	11.5	49.6	35/20
1/2	230/60/1	16.3-19.9	4.0-4.9	6.3	22.3	20/10
3/4	230/60/1	11.1-13.6	2.7-3.3	8.3	32.0	25/15
1	230/60/1	10.6-13.0	2.5-3.1	9.7	41.2	30/20
1-1/2	230/60/1	7.4-9.1	1.9-2.4	11.0	47.8	35/20

**TABLE II: Recommended Fusing Data -  
PENTEK XE-Series 60 Hz., Single Phase 2 Wire  
Submersible Pump Motors**

HP	Volts/ Hz/Ph	Motor Winding Resistance Ohms	Service Factor Amps	Locked Rotor Amps	Fuze Size Standard/ Dual Element
1/2	115/60/1	1.4-1.7	9.5	36.4	30/20
1/2	230/60/1	4.6-5.6	4.7	19.5	15/10
3/4	230/60/1	3.5-4.3	6.4	24.8	20/15

NOTE: 2 Wire motor leads are not color coded. Overload is located in motor and cannot be tested from above ground.

**TABLE III: Copper Cable Length in Feet (Service to Motor)**

**PENTEK XE-Series Motors: 1 Ph, 3-Wire Cable, 60 Hz. Wire Size**

Volts	HP	14AWG	12AWG	10AWG	8AWG	6AWG	4AWG	3AWG	2AWG	1AWG
115V	1/2	99'	157'	250'	398'	633'	1006'	1269'	1599'	2016'
230V	1/2	361	575	914	1453	2310	3673	4633	5839	7360
	3/4	274	436	694	1103	1753	2788	3517	4432	5587
	1	235	373	593	944	1500	2385	3009	3793	4781
	1-1/2	207	329	523	832	1323	2104	2653	3344	4216

**PENTEK XE-Series Motors: 1 Ph, 2-Wire Cable, 60 Hz. Wire Size**

Volts	HP	14AWG	12AWG	10AWG	8AWG	6AWG	4AWG	3AWG	2AWG	1AWG
115V	1/2	120'	191'	303'	482'	766'	1218'	1536'	1936'	2441'
230V	1/2	485	770	1225	1947	3096	4923	6210	7827	9866
	3/4	356	566	899	1430	2274	3615	4561	5748	7245

**TABLE III-M: Copper Cable Length in Meters (Service to Motor)**

**PENTEK XE-Series Motors: 1 Ph, 3-Wire Cable, 60 Hz. Wire Size in mm<sup>2</sup>**

Volts	HP	KW	2.5	4	6	10	16	25	35	50	70
115V	1/2	.37	30m	48m	76m	121m	193m	307m	387m	488m	615m
230V	1/2	.37	110	175	278	443	704	1119	1412	1780	2243
	3/4	.55	84	133	211	336	534	850	1072	1351	1703
	1	.75	72	114	181	288	457	727	917	1156	1457
	1-1/2	1.1	63	100	160	254	403	641	809	1019	1285

**PENTEK XE-Series Motors: 1 Ph, 2-Wire Cable, 60 Hz. Wire Size in mm<sup>2</sup>**

Volts	HP	KW	2.5	4	6	10	16	25	35	50	70
115V	1/2	.37	37m	58m	92m	147m	233m	371m	468m	590m	744m
230V	1/2	.37	148	235	373	594	944	1501	1893	2386	3007
	3/4	.55	108	172	274	436	693	1102	1390	1750	2208

**TABLE IV: PENTEK Motor/Control Coordination**

XE-Series Motor Model No. (3-W)	HP	Volts/Hz/Ph	SMC Submersible Motor Control Type CSIR CSCR	
P43B0005A1	1/2	115/60/1	SMC-IR0511	-
P43B0005A2	1/2	230/60/1	SMC-IR0521	SMC-CR0521
P43B0007A2	3/4	230/60/1	SMC-IR0721	SMC-CR0721
P43B0010A2	1	230/60/1	SMC-IR1021	SMC-CR1021
P43B0015A2	1-1/2	230/60/1	-	SMC-CR1521

NOTE: PENTEK XE- and T-Series Motors with model numbers beginning 'P42' or 'P42T' are 2-Wire motors and do not use a Submersible Motor Control.

**PENTEK T-Series Motor, Submersible Motor Control, and Fusing/Wiring Specifications.**

**TABLE V: Recommended Fusing Data - PENTEK T-Series 60 Hz., Single Phase, 3 Wire Induction Run Submersible Pump Motors**

HP	Volts/Hz/Ph	Motor Winding Resistance-Ohms		Service Factor Amps	Locked Rotor Amps	Fuze Size Standard/Dual Element/CB
		Main	Start			
1/2	230/60/1	3.7	8.6	5.5	19	20/10/15
3/4	230/60/1	2.5	4.8	7.4	25	25/15/20
1	230/60/1	1.9	4.2	8.9	38	30/20/25
1-1/2	230/60/1	1.45	3.3	12.7	49	35/20/30
2	230/60/1	1.3	2.45	12.8	50	30/20/25
3	230/60/1	1.1	2.87	17.1	55	45/30/40
5	230/60/1	0.8	1.7	25.9	83	80/45/60

**TABLE VI: Recommended Fusing Data - PENTEK T-Series 60 Hz., Single Phase 2 Wire Submersible Pump Motors**

HP	Volts/Hz/Ph	Motor Winding Resistance Ohms	Service Factor Amps	Locked Rotor Amps	Fuze Size Standard/Dual Element/CB
1/2	230/60/1	4	5.5	19.0	20/10/15
3/4	230/60/1	2.47	7.4	25.0	25/15/20
1	230/60/1	1.87	8.9	38	30/20/25

**NOTE:** 2 Wire motor leads are not color coded. Overload is located in motor and cannot be tested from above ground.

**TABLE VII: PENTEK T-Series Motor/Control Coordination**

T-Series Motor Model No. (3-W)	HP	Volts/Hz/Ph	SMCT Submersible Motor Control Type	
			CSCR	CSCR
P43T0005A2	1/2	230/60/1	SMCT-CR0521	-
P43T0007A2	3/4	230/60/1	SMCT-CR0721	-
P43T0010A2	1	230/60/1	SMCT-CR1021	-
P43T0015A2	1-1/2	230/60/1	SMCT-CR1521	-
P43T0020A2	2	230/60/1	SMCT-CR2021	SMCT-CRP2021
P43T0030A2	3	230/60/1	SMCT-CR3021	SMCT-CRP3021
P43T0050A2	5	230/60/1	SMCT-CR5021	SMCT-CRP5021

**NOTE:** PENTEK XE- and T-Series Motors with model numbers beginning 'P42' or 'P42T' are 2-Wire motors and do not use a Submersible Motor Control.

**A Note on Nomenclature:**

**Submersible Motor Control:** The box, including the terminal strip(s), capacitor(s), relay(s), etc, which controls the basic on/off functions for a submersible motor.

**Variable Speed Drive:** A programmable motor control that varies pump speed to maintain constant pressure under varying load conditions.

**Submersible Motor Control Compatibility**

Motor Type	Submersible Motor Control Type		
	SMC	Franklin	SMCT
PENTEK XE-Series	Yes	Yes	<b>NO</b>
Franklin	Yes	Yes	<b>NO</b>
PENTEK T-Series	<b>NO</b>	<b>NO</b>	Yes

**TABLE VIII: Copper Cable Length in Feet (Service to Motor)**

**PENTEK T-Series Motors: 1 Phase, 3- or 2-Wire Cable, 60 Hz. Wire Size**

Volts	HP	14AWG	12AWG	10AWG	8AWG	6AWG	4AWG	3AWG	2AWG	1AWG
115V	1/2	104'	165'	262'	416'	662'	1052'	1327'	1672'	2109'
230V	1/2	414	658	1047	1664	2646	4207	5307	6689	8438
	3/4	308	489	778	1237	1967	3127	3944	4971	6271
	1	256	407	647	1028	1635	2600	3280	4134	5214
	1-1/2	179	285	453	721	1146	1822	2298	2897	3654
	2	178	283	450	715	1137	1808	2280	2874	3626
	3	133	212	337	535	851	1353	1707	2151	2714
	5	—	—	222	353	562	893	1127	1420	1792

**PENTEK T-Series Motors: 3 Phase, 60 Hz. Wire Size**

Volts	HP	14AWG	12AWG	10AWG	8AWG	6AWG	4AWG	3AWG	2AWG	1AWG
230	5	119	189	300	477	758	1205	1520	1916	2417
	7-1/2	—	—	221	352	560	890	1123	1415	1785
460	3	759	1207	1919	3051	4851	7713	9729	12263	15469
	5	474	754	1199	1907	3032	4821	6081	7664	9668
	7.5	350	557	886	1408	2239	3560	4490	5660	7140
	10	274	436	694	1103	1753	2788	3517	4432	5591

All cable lengths meet NEC for jacketed 60°C copper cable. Based on 3-Wire Induction Run requirements; Capacitor Run requirements may vary. Local code requirements may vary. For aluminum cable, go up two sizes from chart (for example, if the chart calls for No. 10 AWG for copper, go to No. 8 AWG for aluminum; the smaller the number, the larger the cable). Use oxidation inhibitors on the connections.

**TABLE VIII-M: Copper Cable Length in Meters (Service to Motor)**

**PENTEK T-Series Motors: 1 Phase, 3- or 2- Wire Cable, 60 Hz. Wire Size in mm<sup>2</sup>**

Volts	HP	KW	2.5	4	6	10	16	25	35	50	70
115V	1/2	.37	31m	50m	79m	126m	214m	320m	404m	509m	642m
230V	1/2	.37	126	200	319	507	806	1282	1617	2038	2571
	3/4	.55	93	149	237	377	599	953	1202	1515	1911
	1	.75	78	124	197	313	498	792	999	1260	1589
	1-1/2	1.1	54	86	138	219	349	555	700	883	1115
	2	1.5	54	86	137	217	346	551	694	876	1105
	3	2.2	40	64	102	163	259	412	520	655	827
	5	3.7	—	—	67	107	171	272	343	432	546

**PENTEK T-Series Motors: 3 Phase, 60 Hz. Wire Size in mm<sup>2</sup>**

Volts	HP	KW	2.5	4	6	10	16	25	35	50	70
230V	5	3.7	36	57	91	145	231	367	463	584	735
	7-1/2	5.5	—	—	67	107	170	271	342	431	544
460V	3	2.2	231	367	584	929	1478	2350	2965	3737	4714
	5	3.7	144	229	365	581	924	1469	1853	2335	2946
	7-1/2	5.5	106	169	270	429	682	1085	1368	1725	2176
	10	7.5	83	132	211	336	534	240	1071	1350	1704

All cable lengths meet NEC for jacketed 60°C copper cable. Based on 3-Wire Induction Run requirements; Capacitor Run requirements may vary. Local code requirements may vary. For aluminum cable, go up two sizes from chart (for example, if the chart calls for No. 10 AWG for copper, go to No. 8 AWG for aluminum; the smaller the number, the larger the cable). Use oxidation inhibitors on the connections.

**NOTE**

Specifications on pages 4 to 7 are for  
PENTEK motors only. For Franklin  
specifications, see Pages 8 to 11.

**PENTEK T-Series 3-Phase 4" MOTOR OVERLOAD PROTECTION**

PENTEK T-Series 3-phase submersible motors must have Class 10 overload protection that will disconnect the power within 10 seconds in the case of a locked rotor. To accomplish this, fixed-heater overloads are used. Refer to the chart below for appropriate heaters. The chart is based upon total line amps.

Divide the motor amps by 1.732 when using a 6-lead motor with a Y-Delta Starter.

NOTICE: General Electric overload heaters are only usable with General Electric overload relays.

Do not adjust relays to exceed nameplate amps.

For reliable 3-Phase starter operation, length of wire between starter and service entrance should be not more than 25% of total wire length.

**TABLE IX: PENTEK T-Series Three-Phase Motor Overload Protection (60 Hz, 3450 RPM)**

Motor Type	PENTEK Part Number	HP	kW	Volts	NEMA Starter Size	Overload Heater Relays†			Adjustable Relays	
						Allen Bradley	Furnas	Set G.E.	Max. Amps	Amps
4" 3-Wire	P43T0030A4	3	2.2	460	0	J21	K37	L618A	5.6	6.0
	P43T0050A3	5	3.7	230	1	J33	K61	L199B	20.0	22.0
	P43T0050A4	5	3.7	460	0	J26	K49	L100B	8.9	9.6
	P43T0075A3	7-1/2	5.5	230	1	J37	K67	L293B	24.0	26.0
	P43T0075A4	7-1/2	5.5	460	1	J30	K55	L147B	12.0	13.0
	P43T0100A4	10	7.5	460	1	J33	K60	L199B	15.4	16.6

\* Table data are generated per NEC and Heater Manufacturer Recommendations (see 2005 NEC-Chapter 3, Tables 430.52, 430.248, 430.250, Allen Bradley, Siemens (Furnas) and G.E. catalogs for more information).

† Class 10 protection required. Warranty is void if Class 10 protection is not used.

**TABLE X: Recommended Fusing Data - PENTEK T-Series 60 Hz., 3 Phase Submersible Pump Motors**

HP	Volts/Hz/Ph	Motor Winding Resistance Ohms	Service Factor Amps	Locked Rotor Amps	Fuze Size Standard/Dual Element
3	460/60/3	5.72-4.68	6.0	40	15/10
5	230/60/3	0.90-0.73	22.0	132	50/30
5	460/60/3	3.70-3.02	9.6	66	25/15
7-1/2	230/60/3	0.62-0.50	26.0	180	80/45
7-1/2	460/60/3	2.60-2.10	13.0	90	40/25
10	460/60/3	2.20-1.80	16.6	110	60/30

**NOTE**

Specifications on pages 4 to 7 are for PENTEK motors only. For Franklin specifications, see Pages 8 to 11.

**TABLE XI – Overloads for 3 Phase 60 Hertz 4" Franklin Electric Motors**

HP	KW	Volts	NEMA Starter Size	Heaters for Overload Relays			Adjustable Relays (Note 4)	
				Furnas (Note 1)	Allen Bradley (Note 2)	GE (Note 3)	Set	Max.
				1.5	1.1	230 460 575	00 00 00	K39 K29 K26
2	1.5	230 460 575	0 00 00	K49 K33 K29	J25 J18 J15	L910A L463A L380A	7.5 3.8 3.0	8.1 4.1 3.2
3	2.2	230 460 575	0 0 0	K52 K37 K34	J28 J21 J19	L122B L618A L510A	10.1 5.1 4.1	10.9 5.5 4.4
5	3.7	230 460 575	1 0 0	K61 K49 K42	J33 J26 J23	L199B L100B L825A	16.6 8.3 6.6	17.8 8.9 7.1
7.5	5.5	230 460 575	1 1 1	K67 K55 K52	J37 J30 J28	L293B L147B L122B	24.6 12.3 9.9	26.4 13.2 10.6
10	7.5	460 575	1 1	K61 K57	J33 J31	L220B L181B	17.5 14.0	18.8 15.0

**TABLE IX NOTES:**

**NOTE 1:** Furnas intermediate sizes between NEMA starter sizes apply where (1) is shown in tables, size 1-3/4 replacing 2, 2-1/2 replacing 3, 3-1/2 replacing 4 and 4-1/2 replacing 5. Heaters were selected from Catalog 294, Table 332 and Table 632 (starter size 00, size B). Size 4 starters are heater type 4 (JG). Starters using these heater tables include classes 14, 17 and 18 (INNOVA), classes 36 and 37 (reduced voltage), and classes 87, 88 and 89 (pump and motor control centers). Overload relay adjustments should be set no higher than 100% unless necessary to stop nuisance tripping with measured amps in all lines below nameplate maximum. Heater selections for class 16 starters (Magnetic Definite Purpose) will be furnished upon request.

**NOTE 2:** Allen-Bradley heaters were selected from Catalog IC-110, Table 162 (through starter size 4), Table 547 (starter size 5), and Table 196 (starter size 6). Bulletin 505, 509, 520, 540 and 570 use these heater tables. Heater selections for bulletin 1232X and 1233X starters will be furnished upon request.

**NOTE 3:** General Electric heaters are type CR123 usable only on type CR124 overload relays and were selected from Catalog GEP-126OJ, page 184. Adjustment should be set no higher than 100%, unless necessary to stop nuisance tripping with measured amps in all lines below nameplate maximum.

**NOTE 4:** Adjustable overload relay amp settings apply to approved types listed. Relay adjustment should be set at the specified SET amps. Only if tripping occurs with amps in all lines measured to be within nameplate maximum amps should the setting be increased, not to exceed the MAX value shown.

**Recommended Adjustable Overload Relays**

- AEG Series:** B17S, B27S, B27-2.
- Allen Bradley:** Bulletin 193, SMP-Class 10 only.
- Fanal Types:** K7 or K7D through K400.
- Franklin Electric:** Subtrol-Plus.
- General Electric:** CR4G, CR7G, RT\*1, RT\*2, RTF3, RT\*4, CR324X-Class 10 only.
- Klockner-Moeller Types:** Z00, Z1, Z4, PKZM1, PKZM3, PKZ2.
- Lovato:** RC9, RC22, RC80, RF9, RF25, RF95.
- Siemens Types:** 3UA50, -52, -54, -55, -58, -59, -60, -61, -62, -66, -68, -70, 3VUI3, 3VE, 3UB (Class 5).
- Sprecher and Schuh Types:** CT, CT1, CTA 1, CT3K, CT3-12 thru CT3-42, KTA3, CEF1 & CET3 set at 6 sec. max., CEP 7 Class 10, CT4, 6, & 7, CT3.
- Square D/Telemecanique:** Class 9065 types TD, TE, TF, TG, TJ, TK, TR, TJE, TJF (Class 10) or LR1-D, LR1-F, LR2-D13, -D23, -D33, Types 18A, 32A, SS-Class 10, SR-Class 10 and 63-A-LB Series. Integral 18,32,63, GV2-L, GV2-M, GV2-P, GV3-M (1.6-10 amp only).
- Westinghouse Types:** FT13, FT23, FT33, FT43, K7D, K27D, K67D, Advantage (Class 10), MOR, IQ500 (Class 5).

Other relay types from these and other manufacturers may or may not provide acceptable protection, and they should not be used without approval of Franklin Electric.

Some approved types may only be available for part of the listed motor ratings. When relays are used with current transformers, relay setting is the specified amps divided by the transformer ratio.

**NOTE**  
Specifications on this page are for Franklin motors only. For PENTEK specifications, see Pages 4 to 7.

**TABLE XII: Recommended Fusing Data - Franklin 60 Hz., Single Phase, 3 Wire Standard Submersible Pump Motors**

HP	Volts/Hz/Ph	Motor Winding Resistance-Ohms		Service Factor Amps	Locked Rotor Amps	Fuze Size Standard/Dual Element
		R to Y	B to Y			
1/2	115/60/1	4.1-5.1	1.0-1.3	12.0	50.5	35/20
1/2	230/60/1	16.7-20.5	4.2-5.2	6.0	23.0	20/10
3/4	230/60/1	11.0-13.4	3.0-3.6	8.0	34.2	25/15
1	230/60/1	10.1-12.3	2.2-2.7	9.8	41.8	30/20

**Recommended Fusing Data - Franklin 60 Hz., Single Phase, 3 Wire Capacitor Run Submersible Pump Motors**

HP	Volts/Hz/Ph	Motor Winding Resistance-Ohms		Service Factor Amps	Locked Rotor Amps	Fuze Size Standard/Dual Element
		R to Y	B to Y			
1-1/2	230/60/1	6.2-12.0	1.5-2.3	11.5	52.0	35/20
2	230/60/1	5.2-7.15	1.6-2.3	13.2	51.0	30/20
3	230/60/1	3.0-4.9	0.9-1.5	17.0	82.0	45/30
5	230/60/1	2.1-2.8	0.68-1.0	27.5	121.0	80/45

Red to Yellow = start winding resistance;  
Black to Yellow = main winding resistance.

**TABLE XIII: Recommended Fusing Data - Franklin 60 Hz., Single Phase 2 Wire Submersible Pump Motors**

HP	Volts/Hz/Ph	Motor Winding Resistance-Ohms	Service Factor Amps	Locked Rotor Amps	Fuze Size Standard/Dual Element
1/2	115/60/1	1.0-1.3	12.0	64.4	35/20
1/2	230/60/1	4.2-5.2	6.0	32.2	20/10
3/4	230/60/1	3.0-3.6	8.0	40.7	25/15
1	230/60/1	2.2-2.7	9.8	48.7	30/20
1-1/2	230/60/1	1.5-1.9	13.1	66.6	35/20

NOTE: 2 Wire motor leads are not color coded. Overload is located in motor and cannot be tested from above ground.

**TABLE XIV: Recommended Fusing Data - Franklin 60 Hz, 3 Phase Submersible Pump Motors**

HP	Volts/Hz/Ph	Max Input (S.F. Load) Amps	Line to Line Resistance	Locked Rotor Amps	Fuze Size Standard/Dual Element
1-1/2	230/60/3	5.9	3.2-4.0	33.2	15/10
	460/60/3	3.0	13.0-16.0	16.6	8/5
	575/60/3	2.4	20.3-25.3	13.3	6/4
2	230/60/3	8.1	2.4-3.0	46.6	25/15
	460/60/3	4.1	9.7-12.0	23.3	15/8
	575/60/3	3.2	15.1-18.7	18.6	10/5
3	230/60/3	10.8	1.8-2.2	61.9	30/20
	460/60/3	5.4	7.0-8.7	31.0	15/10
	575/60/3	4.3	10.9-13.6	24.8	15/8
5	230/60/3	17.7	0.93-1.2	106.0	50/30
	460/60/3	8.9	3.6-4.4	53.2	25/15
	575/60/3	7.1	5.6-6.9	42.6	20/15
7-1/2	230/60/3	26.0	0.61-0.75	164.0	80/45
	460/60/3	13.0	2.4-3.4	81.9	40/25
	575/60/3	10.4	3.5-5.1	65.5	30/20
10	460/60/3	18.5	1.8-2.3	116.0	60/45
	575/60/3	14.8	2.8-3.5	92.8	45/35

**NOTE**  
Specifications on this page are for Franklin motors only. For PENTEK specifications, see Pages 4 to 7.

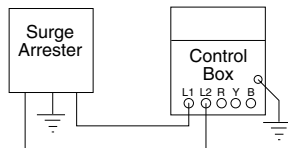

**FIGURE 1 – Typical 3 Wire, Single Phase, 230 Volt Surge Arrester**

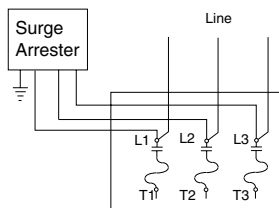

**FIGURE 2 - Three Phase Surge Arrester (650 Volt Maximum)**

**TABLE XV: Cable Length in Feet (Service to Motor)**  
**1 Phase, 3- or 2-Wire Cable, Franklin Motors 60 Hz. Copper Wire Size AWG**

Volts	HP	14 AWG	12 AWG	10 AWG	8 AWG	6 AWG	4 AWG	3 AWG	2 AWG	1 AWG	0 AWG
115V	1/2	100'	160'	250'	390'	620'	960'	1190'	1460'	1780'	2160'
230V	1/2	400	650	1020	1610	2510	3880	4810	5880	7170	8720
	3/4	300	480	760	1200	1870	2890	3580	4370	5330	6470
	1	250	400	630	990	1540	2380	2960	3610	4410	5360
	1-1/2	190	310	480	770	1200	1870	2320	2850	3500	4280
	2	150	250	390	620	970	1530	1910	2360	2390	3620
	3	120*	190	300	470	750	1190	1490	1850	2320	2890
	5	—	—	180	280	450	710	890	1110	1390	1740

**3 Phase, 60 Hz. - Franklin Motors, Copper Wire Size AWG**

Volts	HP	14 AWG	12 AWG	10 AWG	8 AWG	6 AWG	4 AWG	3 AWG	2 AWG	1 AWG	0 AWG
230V	1-1/2	420'	670'	1060'	1670'	2610'	4050'	5030'	6160'	7530'	9170'
	2	320	510	810	1280	2010	3130	3890	4770	5860	7170
	3	240	390	620	990	1540	2400	2980	3660	4480	5470
	5	140*	230	370	590	920	1430	1790	2190	2690	3290
	7-1/2	—	160*	260	420	650	1020	1270	1560	1920	2340
	10	—	—	190*	310	490	760	950	1170	1440	1760
460V	1-1/2	1700	2710	4270	6730	—	—	—	—	—	—
	2	1300	2070	3270	5150	8050	—	—	—	—	—
	3	1000	1600	2520	3970	6200	—	—	—	—	—
	5	590	950	1500	2360	3700	5750	—	—	—	—
	7-1/2	420	680	1070	1690	2640	4100	5100	6260	7680	—
	10	310	500	790	1250	1960	3050	3800	4650	5750	7050
575V	1-1/2	2620	4180	6580	—	—	—	—	—	—	—
	2	2030	3250	5110	8060	—	—	—	—	—	—
	3	1580	2530	3980	6270	5750	—	—	—	—	—
	5	920	1480	2330	3680	5750	—	—	—	—	—
	7-1/2	660	1060	1680	2650	4150	—	—	—	—	—
	10	490	780	1240	1950	3060	4770	5940	—	—	—

\*Meets NEC for individual conductor 60°C cable. Only lengths without \* meet NEC for jacketed 60°C cable. Local code requirements may vary.

**Table XV NOTES:**

- Sizes given are for copper wire. For aluminum wire, go two sizes larger. For example, if table lists #12 (3mm<sup>2</sup>) copper wire, use #10 (5mm<sup>2</sup>) aluminum wire. Use oxidation inhibitors on connections.
- For reliable 3 Phase starter operation, length of wire between starter and service entrance should be not more than 25% of total wire length.

**TABLE XVI: Franklin Control Box Selection**

HP	Voltage	Motor No.	Control Box No.
1/2	115	214304	28010449
		214504	
1/2	230	214305	28010549
		214505	
3/4	230	214307	28010749
		214507	
1	230	214308	28010849
		214508	
1-1/2	230	224300	28230081
2	230	224301	28230181
			28230183
3	230	224302	28230281
			28230283
5	230	224303	28211381
			28211383

**NOTE**

Specifications on this page are for Franklin motors only. For PENTEK specifications, see Pages 4 to 7.

Submersible Motor Control Compatibility			
Motor Type	Submersible Motor Control Type		
	SMC	Franklin	SMCT
PENTEK XE-Series	Yes	Yes	<b>NO</b>
Franklin	Yes	Yes	<b>NO</b>
PENTEK T-Series	<b>NO</b>	<b>NO</b>	Yes

**TABLE XV-M: Cable Length in Meters (Service to Motor)**  
**1 Phase, 3- or 2-Wire Cable, Franklin Motors 60 Hz. Copper Wire Size in mm<sup>2</sup>**

Volts	HP	KW	2.5	4	6	10	16	25	35	50	70
115V	1/2	.37	30m	49m	76m	119m	189m	293m	445m	543m	658m
230V	1/2	.37	122	650	1020	1610	2510	3880	5880	7170	8720
	3/4	.55	91	198	232	366	570	881	1332	1625	1970
	1	.75	76	122	192	302	469	725	1100	1344	1634
	1-1/2	1.1	58	94	146	235	366	570	869	1067	1305
	2	1.5	46	76	390	119	296	466	719	893	1103
	3	2.2	37	58	300	91	229	363	564	707	881
	5	3.7	-	-	55	85	137	216	338	424	530

**3 Phase, 60 Hz. - Franklin Motors, Copper Wire Size in mm<sup>2</sup>**

Volts	HP	KW	2.5	4	6	10	16	25	35	50	70
230V	1-1/2	1.1	120m	204m	323m	509m	796m	1234m	1878m	2295m	2795m
	2	1.5	98	155	247	390	613	954	1454	1786	2185
	3	2.2	73	119	189	189	143	222	340	416	508
	5	3.7	43	70	113	180	280	436	668	820	1003
	7-1/2	5.5	-	49	79	128	198	311	475	585	713
	10	7.5	-	-	58	94	149	232	357	439	536
460V	1-1/2	1.1	518	826	1301	2051	-	-	-	-	-
	2	1.5	396	631	997	1570	2454	-	-	-	-
	3	2.2	305	488	768	1210	1890	-	-	-	-
	5	3.7	180	290	457	719	1128	1753	-	-	-
	7-1/2	5.5	128	207	326	515	805	1250	1908	2341	-
	10	7.5	95	152	241	381	597	930	1417	1753	2149
575V	1-1/2	1.1	799	1274	2006	-	-	-	-	-	-
	2	1.5	619	990	1558	2457	-	-	-	-	-
	3	2.2	482	771	1213	1911	-	-	-	-	-
	5	3.7	280	451	710	1122	1753	-	-	-	-
	7-1/2	5.5	201	323	512	808	1265	-	-	-	-
	10	7.5	149	238	378	594	933	1454	-	-	-

Based on 3-Wire Induction Run requirements; Capacitor Run requirements may vary. Local code requirements may vary. For aluminum cable, go up two sizes from chart (for example, if the chart calls for No. 10 AWG for copper, go to No. 8 AWG for aluminum; the smaller the number, the larger the cable).

**NOTE**  
 Specifications on this page are for Franklin motors only. For PENTEK specifications, see Pages 4 to 7.

**Table XV-M NOTES:**

- Sizes given are for copper wire. For aluminum wire, go two sizes larger. For example, if table lists 4mm<sup>2</sup> (#12) copper wire, use 6mm<sup>2</sup> (#10) aluminum wire. Use oxidation inhibitors on connections.
- For reliable 3 Phase starter operation, length of wire between starter and service entrance should be not more than 25% of total wire length.

### Calculating Cable size when two different sizes can be used.

Sometimes conditions make it desirable to use more than one size cable in an installation.

For example: Replace a pump with a 3 HP, 230 volt, 60 Hz, single phase motor, with the motor setting at 210' down the well and with 160' of #10 cable buried between the service entrance and the well head. In order to avoid replacing the buried cable, the question is: What size cable is required in the well? Calculate as follows:

1. According to Table VIII, a total of 280' of #10 cable is allowed to power the 3 HP motor. The per cent of this total that has been used by the 160' of cable in the buried run is:  $160' / 280' = .571 = 57.1\%$ .

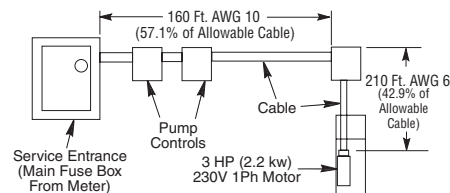

2. With 57.1% of the allowable cable already used, 42.9% of the total length is left for use in the well. To avoid running a cable that is too long and lowering the voltage to the motor, we have to find a cable size large enough so that 210' is less than 42.9% of the total length allowed for that size.
3. Trying #8 cable, Table VIII shows that the total allowable length for a 3 HP motor is 443'.  $443' \times 42.9\% = 443' \times .429 = 190.0'$   
This is not long enough.
4. Trying #6 cable, Table VIII shows that the total allowable length is 689'.  $689' \times 42.9\% = 689' \times .429 = 295.6'$   
This is longer than needed. Therefore, #6 cable can be used for the 210' of cable in the well.  
Any combination of sizes can be used, provided that the total percentage of the length of the two sizes of cable does not exceed 100% of the allowed lengths.

### Calculating Cable size when two different sizes can be used.

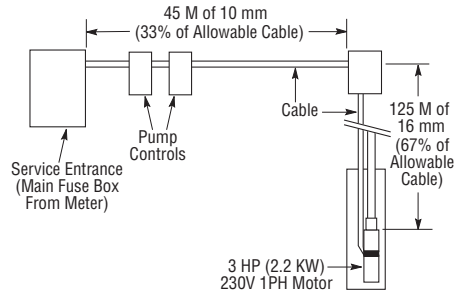

Example (Metric): When replacing pump motor in an installation already having 45M of buried 10 mm<sup>2</sup> cable between service entrance and well head, what size cable is required in the well (from well head to motor) when using a 3 HP (2.2kw), 230 volt, single phase motor set 125M below the well head?

Solution (Metric): According to Table VIII-M, 135M is the maximum allowable length when using 10 mm<sup>2</sup> cable with a 3 HP (2.2kw) 1Ø motor. The installation has 45M already in place.

$45M \text{ (used)} \div 135M \text{ (allowed)} = 33\%$ .  
Approximately 33% of allowable cable has been used. That leaves approximately 67% of allowable cable still available for use in the well.

According to Table VIII-M, 16 mm<sup>2</sup> cable can be used to a maximum of 210M.  $67\% \text{ of } 210M = 140M$ ; this is more than the length required, therefore 16 mm<sup>2</sup> wire can be used.

NOTICE: When figuring the percent of cable length of any size that can be used, remember that the total percentages of all sizes cannot add to more than 100%.

## INSTALLATION WIRING DIAGRAMS - SINGLE PHASE, 3 WIRE

**▲ WARNING** For motors of 1-1/2 HP and above, use magnetic starter to avoid damage to pressure switch. Consult factory for wiring information.

**▲ WARNING** Hazardous voltage. Can shock, burn, or kill.

Ground control box, all metal plumbing, and motor frame with copper wire in compliance with local codes. Use a ground wire at least as large as the wires supplying power to motor.

Permanently close all unused openings in this and other equipment.

Disconnect power to control box before working on or around control box, pipes, cable, pump, or motor.

To be sure that starting relay will function and that overload will not “nuisance trip”, install control box vertically with top side up.

Wire control box as shown on Pages 14 through 18. Pump will not operate without control box, and some boxes require a switch or a jumper lead between ‘SW’ and ‘L2’ terminals. Operation without control box will burn out motor.

Installation must meet United States National Electrical Code, Canadian Electrical Code, and local codes for all wiring (as applicable).

If main overload trips, look for:

1. Shorted Capacitor

2. Voltage Problems

3. Overloaded or locked pump.

**NOTICE:** Match motor to control box or submersible motor control as shown on pages 4, 5 and 10. Franklin motor and control box model numbers may include additional suffix numbers to the right of the numbers shown here. These additional numbers are not important for control box selection.

### LIQUID LEVEL (PUMP DOWN)

#### CONTROLS:

Use pump down controls on wells with low flow to prevent pumping well dry. See Wiring diagrams, Pages 14 through 18, for proper installation.

**NOTICE:** Ground controls according to local code requirements.

If start overload trips, replace start relay. Reset and analyze for tripping cause. To avoid motor burnout, do not remove or short circuit overload protection.

**CHECKING PROCEDURE (ALL BOXES):**

**⚠ DANGER** Hazardous voltage. Can shock, burn, or cause death. Disconnect power to control box before doing these check procedures.

- A. General Procedures.** (Power to control box disconnected)
1. Disconnect line.
  2. Inspect for damaged or burned parts, loose connections, etc.
  3. Check for misconnections against diagram in control box.
  4. If box is too hot, circuit breakers may trip or fuses blow. Ventilate or shade box. Move away from heat source.
  5. If problem has not been found, check motor and control box. Use test procedures that follow.

- B. Ground (Insulation Resistance) Test.** (Power to control box disconnected)
1. Ohmmeter Setting: Highest scale (usually Rx100K or Rx10,000).
  2. Terminal Connections: One ohmmeter lead to "Ground" screw on control box and touch other lead to each of the terminals on terminal board.
  3. Ohmmeter Reading: Pointer should remain at infinity ( $\infty$ ) and not deflect.

**C. Capacitor Tests.** (Power to control box disconnected)

**⚠ WARNING** Risk of electric shock. Short capacitor across terminals before testing.

1. Ohmmeter Setting: Rx1000.
2. Terminal Connections: Connect ohmmeter leads to black and orange wires out of capacitor case.
3. Ohmmeter Reading: Pointer should swing toward "zero" and "float" back to ( $\infty$ ). Capacitor is shorted if pointer does not move back to ( $\infty$ ), open if it does not move from ( $\infty$ ).
4. To reset capacitor, reverse ohmmeter connection to capacitor terminals.

**D. Triac Test.** (Solid state switch only)

1. Ohmmeter Setting: Rx1000.
2. Connect the leads to "R" (start) terminal and to orange lead terminal on start switch.
3. Ohmmeter reading: Infinity ( $\infty$ ).

**E. Coil Test.** (Solid state switch only)

1. Ohmmeter Setting: Rx1.
2. Connect leads to "Y" (common) and L2 terminal and to orange lead terminal on start switch.
3. Ohmmeter reading: Infinity ( $\infty$ ).

**Installation Wiring Diagrams – Single Phase, 3 Wire**

**⚠ WARNING** For motors of 1-1/2 HP and above, use magnetic starter to avoid damage to pressure switch. Consult factory for wiring information.

SINGLE PHASE - 1/2 HP THRU 5 HP STANDARD CONTROL BOX WITH ADEQUATE RATED PRESSURE SWITCH

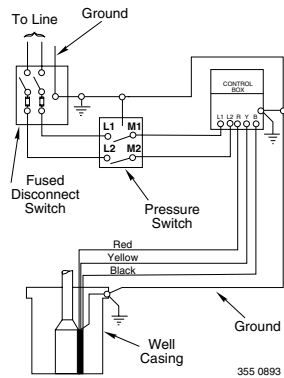

SINGLE PHASE - 1/2 HP THRU 5 HP STANDARD CONTROL BOX WITH PRESSURE SWITCH (One pump for 2 houses) With adequate rated pressure switch

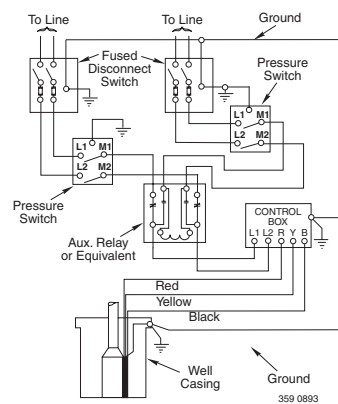

Follow color coding when connecting control box (Yellow to Y, Red to R, Black to B).

### Installation Wiring Diagrams – Single Phase, 3 Wire

**⚠ WARNING** For motors of 1-1/2 HP and above, use magnetic starter to avoid damage to pressure switch. Consult factory for wiring information.

SINGLE PHASE - 1/2 HP THRU 5 HP STANDARD CONTROL BOX WITH LIQUID LEVEL CONTROL

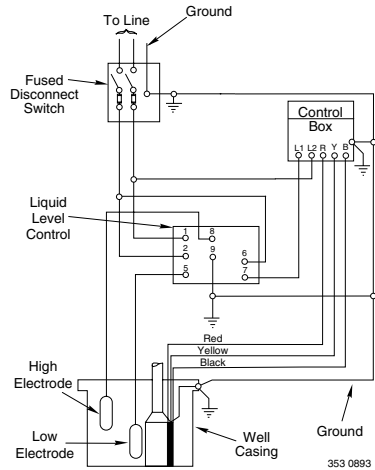

SINGLE PHASE - 1/2 HP THRU 5 HP STANDARD CONTROL BOX WITH PRESSURE SWITCH & LIQUID LEVEL CONTROL

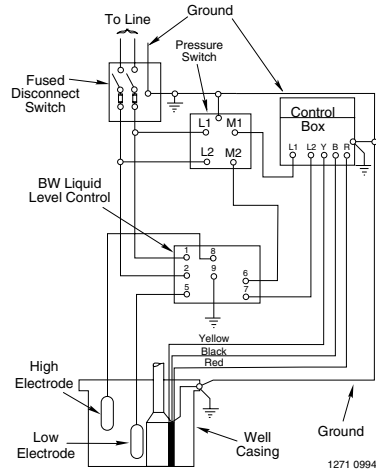

OPEN SYSTEM-SINGLE PHASE - 1/2 HP THRU 5 HP STANDARD CONTROL BOX

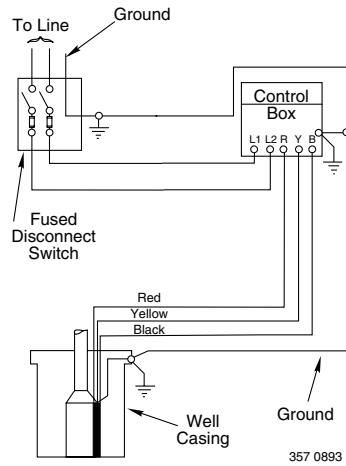

SINGLE PHASE - 2, 3 & 5 HP DELUXE CONTROL BOXES WITH PRESSURE SWITCH

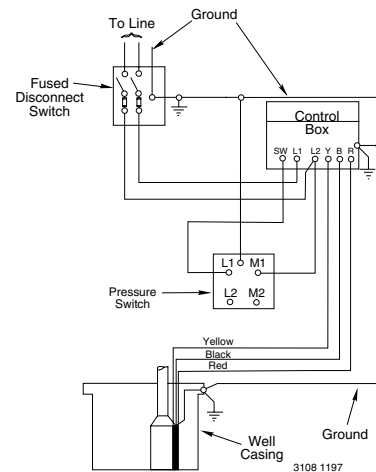

Follow color coding when connecting control box (Yellow to Y, Red to R, Black to B).

### Installation Wiring Diagrams – Single Phase, 3 Wire

**⚠ WARNING** For motors of 1-1/2 HP and above, use magnetic starter to avoid damage to pressure switch. Consult factory for wiring information.

SINGLE PHASE - 1/2 HP THRU 5 HP STANDARD CONTROL BOX WITH LIQUID LEVEL CONTROL

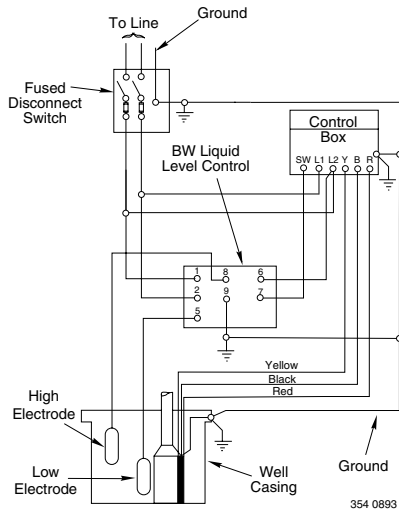

SINGLE PHASE - 1/2 HP THRU 5 HP STANDARD CONTROL BOX WITH PRESSURE SWITCH & LIQUID LEVEL CONTROL

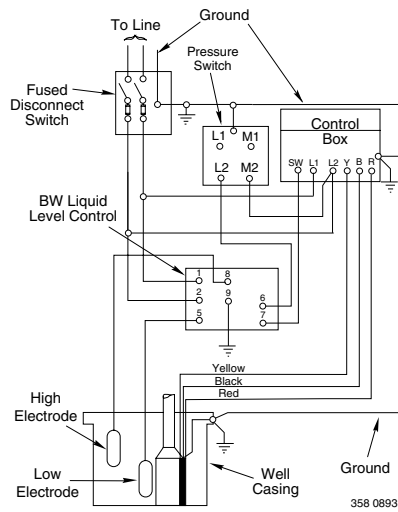

OPEN SYSTEM-SINGLE PHASE - 1/2 HP THRU 5 HP STANDARD CONTROL BOX

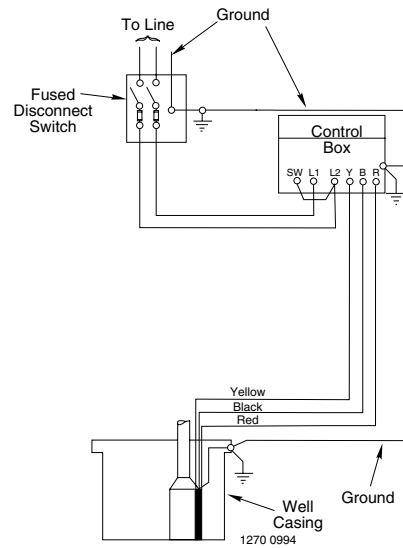

Follow color coding when connecting control box (Yellow to Y, Red to R, Black to B).

### Installation Wiring Diagrams – Three Phase

THREE PHASE - 1-1/2 HP & LARGER  
WITH PRESSURE SWITCH

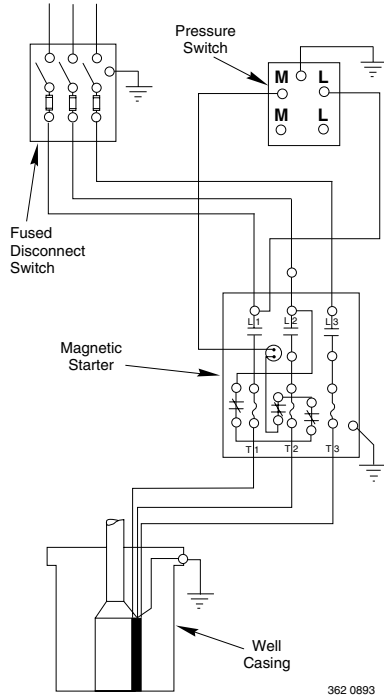

THREE PHASE - 1-1/2 HP & LARGER  
WITH PRESSURE SWITCH &  
LIQUID LEVEL CONTROL

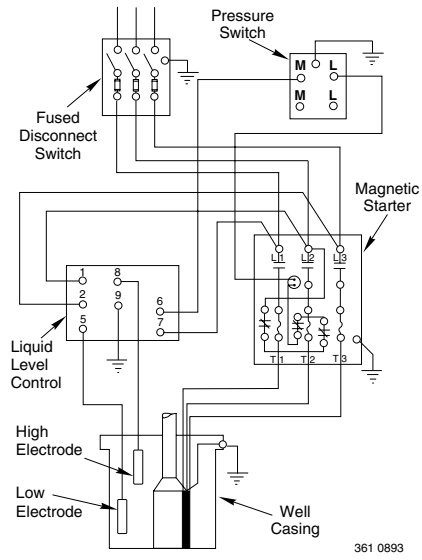

**Follow color coding when connecting control box (Yellow to Y, Red to R, Black to B).**

### Installation Wiring Diagrams – 2 Wire

**⚠ WARNING** For motors of 1-1/2 HP and above, use magnetic starter to avoid damage to pressure switch. Consult factory for wiring information.

WITH PRESSURE SWITCH AND LIQUID LEVEL CONTROL

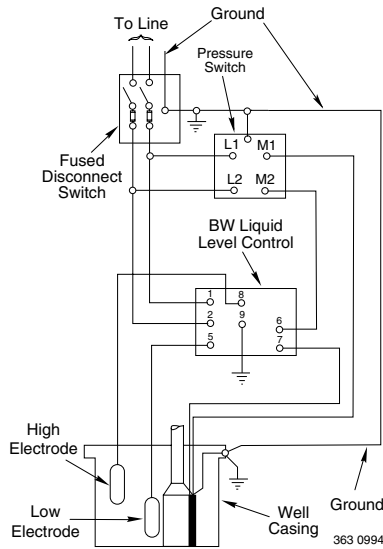

ONE PUMP FOR TWO HOUSES WITH PRESSURE SWITCH

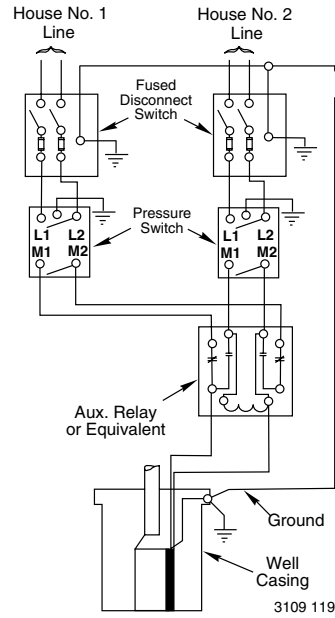

ONE PUMP FOR ONE HOUSE WITH PRESSURE SWITCH

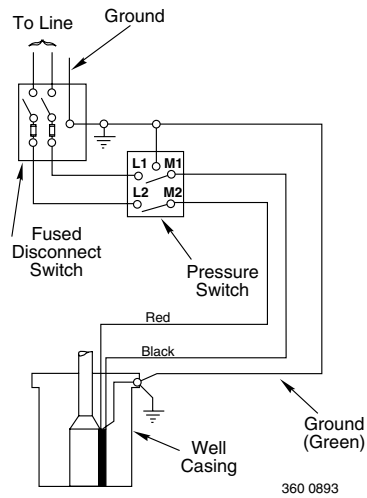

Follow color coding when connecting control box (Yellow to Y, Red to R, Black to B).

## Installation

### CABLE SPLICING:

1. Splice cable to motor leads. Use one of the three methods outlined below. Use only copper wire for connections to pump motor and control box.

#### A. Taped splice (Wire sizes No. 8 (8.4mm<sup>2</sup>) and larger):

1. Cut off motor leads. Stagger lead and wire length so that 2nd lead is 2" (50mm) longer than 1st lead and 3rd lead is 2" (50mm) longer than second.
2. Cut off cable ends. Be sure to match colors and lengths of wires in drop cable to colors and lengths of motor leads.
3. Trim insulation back 1/2" (13mm) from cable ends and motor lead ends.
4. Insert motor lead ends and cable ends into butt connectors (see Figure 4). Be sure to match wire colors between drop cable and motor leads.
5. Using crimping pliers (Figure 7), indent butt connector lugs (see Figure 5) to attach wires.



FIGURE 4



FIGURE 5



FIGURE 6

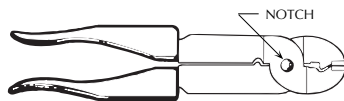

FIGURE 7



FIGURE 8

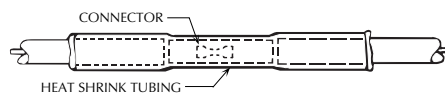

FIGURE 9

6. Cut "Scotchfil" electrical insulation putty into 3 equal parts and form tightly around butt connectors. Be sure scotchfil overlaps insulated part of wire.
7. Using #33 Scotch tape, wrap each joint tightly; cover wire for about 1-1/2" (38mm) on each side of joint. Make four passes with the tape. In other words, when finished you should have four layers of tape tightly wrapped around the wire. Press edges of tape firmly down against the wire (see Figure 8).

**NOTICE:** Since the tightly wound tape is the only means of keeping water out of the splice, the efficiency of the splice will depend on the care used in wrapping the tape.

**NOTICE:** For wire sizes larger than #8, (8.4mm<sup>2</sup>) use a soldered joint rather than Scotchfil putty (see Figure 6).

#### B. Heat-shrink splice (For wire sizes #14, 12 and 10 AWG, or 2, 3, and 5.5mm<sup>2</sup>):

1. Remove 3/8" (10mm) insulation from ends of motor leads and drop cable wires.
2. Put plastic heat shrink tubing over motor leads.
3. Match wire colors and lengths in drop cable to wire colors and lengths of motor leads.
4. Insert cable and motor wire ends into butt connectors and crimp (See Figures 4 and 5). **BE SURE** to match wire colors between drop cable and motor leads. Pull leads to check connections.
5. Center tubing over butt connector and apply heat evenly with a torch (a match or lighter will not supply enough heat).

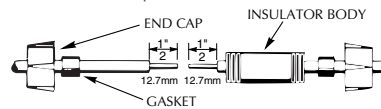

FIGURE 10

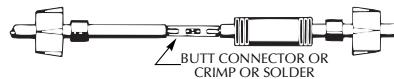

FIGURE 11

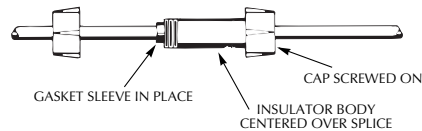

FIGURE 12

**NOTICE:** Keep torch moving. Too much concentrated heat may damage tubing (see Figure 9).

**C. Butt Connectors** with plastic insulators (for 14, 12 and 10 Gauge AWG Wire, or 2, 3 and 5.5mm<sup>2</sup> wire):

1. Cut off motor leads. Stagger lead and wire length so that 2nd lead is 4" (100mm) longer than 1st lead and 3rd lead is 4" (100mm) longer than second.
2. Cut off cable ends. Be sure to match colors and lengths of wires in drop cable to colors and lengths of motor leads.
3. Trim insulation back 1/2" (13mm) from cable ends and motor lead ends.
4. Unscrew plastic caps from insulators. Place a cap and a neoprene gasket sleeve on each wire end to be spliced (see Figure 10).
5. Slide insulator body onto one wire end (Figure 10).
6. Insert wire end into butt connector and crimp (see Figure 11). **Be sure** to match cable and motor wire colors.
7. Center insulator body over splice and slide neoprene sleeves into body as far as they will go. Screw caps onto insulator body (Figure 12) and tighten by hand for a strong, waterproof splice.

#### CABLE INSTALLATION

1. To test submersible, momentarily connect it to proper power supply. Power supply frequency and voltage must match motor nameplate frequency and voltage to within  $\pm 10\%$ . (3 Phase pumps – see "Rotation," Page 3).
2. Fasten cable leads securely to pump discharge section; leave 4-5" (100-127mm) of slack in leads at this point. Securely fasten leads to plastic pipe within 6" (150mm) of the pump discharge section. Use torque arresters to protect pump and pipe from twisting damage as pump starts and stops.
3. Connect copper ground wire to motor bracket. Ground wire must be at least as large as wires supplying current to motor. Consult current National Electrical Code, Canadian Electrical Code and local codes (as applicable) for grounding information.
4. Use only submersible cable supplied by pump manufacturer. When lowering pump into well, secure cable to discharge pipe at 10' (3.5M) intervals with Scotch #33 electrical tape. Take care not to damage pump cable.  
**NOTICE:** To avoid dropping the pump down the well or damaging cable or cable splices, **NEVER** allow pump cable to support weight of pump.

#### PUMP INSTALLATION

1. If a standard air over water pressure tank is being used, install two bleeder orifices about 2' (.6M) apart as shown in Figure 15, Page 21. These orifices will automatically charge the tank with air. See Figure 15 to determine orifice location.  
**NOTICE:** If Pre-charged tank is used, **DO NOT** install bleeder orifices. If pump and pre-charged tank are replacing a standard tank system, remove bleeder orifices before installing pump in well.
2. To prevent losing pump down the well, connect a safety rope strong enough to support pump and drop pipe (minimum 5/16" (8mm) twisted polypropylene or pronila rope) to eyelet on pump discharge. Tie off other end of safety rope securely to well seal, well cap or pitless adapter.
3. Discharge outlet is threaded 2" NPT (60 Hz) or 2" BSP (50 Hz).  
Use 100 PSI rated polyethylene plastic pipe for installations up to 100' depth.  
Use 160 PSI rated polyethylene plastic pipe for installation up to 220' depth.  
For depths beyond 220', use galvanized steel pipe for the entire drop pipe.

#### INITIAL START-UP

**NOTICE:** NEVER operate pump with discharge valve completely closed. Pump can destroy itself if run with discharge shut off ("deadheaded") and warranty will be void.

**NOTICE:** To avoid sand-locking pump, follow procedure below when starting pump for the first time. NEVER start a pump with discharge completely open unless you have done this procedure first.

1. Connect a pipe elbow, a short length of pipe and a gate valve to pump discharge at well head (see Figure 13).
2. Mount motor control box (3-wire pump), fused disconnect switch (2-wire pump), or magnetic starter (3-phase pump) in a permanently weather proofed place. Make sure that controls will not be subjected to extreme heat or excess moisture.
3. Make sure controls are in OFF position.
4. Connect motor leads and power supply to motor control box, fused disconnect switch, or magnetic starter (see Wiring Diagrams, Pages 14 through 18). **DO NOT START PUMP YET.**
5. Set gate valve on discharge 1/3 open; start pump (see Figure 13).
6. Keep gate valve at this setting while water pumps out on ground. Let it run until water is clear of sand or silt. (To check solids in water, fill a glass from pump and let solids settle out).

7. When water is completely clear at 1/3 setting, open gate valve to approximately two-thirds open and repeat process.
8. When water is completely clear at 2/3 setting, open gate valve completely and run pump until water is completely clear.
9. Remove gate valve for permanent installation near tank (see Figures 14 and 15, Pages 22 and 23).
10. Install sanitary well seal or pitless adapter unit, well unit, electrical conduit and surface piping according to local code requirements.

### EFFLUENT APPLICATIONS

Pumps designed and tested for effluent applications must meet the following:

- ▲WARNING Risk of electric shock.** Do not remove cord and strain relief. Do not connect conduit to pump.
1. Only qualified personnel should install the pump and associated control equipment.
  2. Vent sewage or septic tank according to local codes.
  3. Do not install pump in any location classified as hazardous by National Electrical Code, ANSI/NFPA 70-1984.
  4. These pumps are intended for permanent connection only. Provide strain relief at control box for power supply cord connection to box. All control components must be UL listed and suitable for end use application.

### CONNECTING TO TANK/WATER SYSTEM

**▲WARNING Hazardous pressure.** Submersible pumps can develop very high pressure in some situations. To prevent tank blowup, install a pressure relief valve able to pass full pump flow at 75 PSI (517 kPa) when using an air over water pressure tank. Install a pressure relief valve capable of passing entire pump flow at 100 PSI (690 kPa) when using a pre-charged pressure tank. Install this relief valve between pump and tank.

**NOTICE:** Allowing pump or piping system to freeze may severely damage pump and will void warranty. Protect pump and entire piping system (including pressure tank) from freezing.

#### Standard Tank Hookup:

See Figure 15, Page 23 for piping connections to standard pressure tank and for correct distance of bleeder orifices from pressure tank.

#### Pre-charged Pressure Tank Hookup:

See Figure 14, Page 22 for piping connections to pre-charged pressure tank.

**NOTICE:** Check air pre-charge in tank before starting pump. Adjust pre-charge to 2 PSI (13.8 kPa) below pump cut-in setting. (For example, a

pre-charge tank used with a 30-50 switch should be pre-charged with air to 28 PSI (193 kPa). Adjust pre-charge by either adding or bleeding air through tire valve located on top of tank. Check pre-charge annually and adjust as needed.

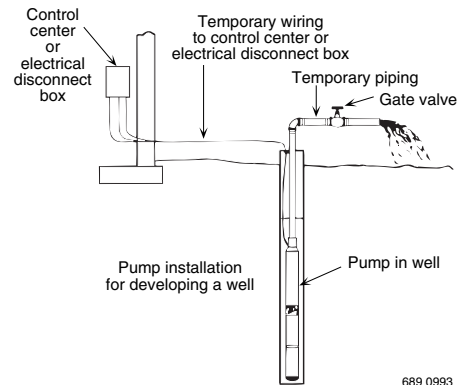

FIGURE 13

### Important Electrical Grounding Information

**▲WARNING Hazardous voltage. Can shock, burn, or kill. To reduce the risk of electrical shock during pump operation, ground and bond the pump and motor as follows:**

- A. To reduce risk of electrical shock from metal parts of the assembly other than the pump, bond together all metal parts accessible at the well head (including metal discharge pipe, metal well casing, and the like). Use a metal bonding conductor at least as large as the power cable conductors running down the well to the pump's motor.
- B. Clamp or weld (or both if necessary) this bonding conductor to the grounding means provided with the pump, which will be the equipment-grounding terminal, the grounding conductor on the pump housing, or an equipment-grounding lead. The equipment-grounding lead, when provided, will be the conductor having green insulation; it may also have one or more yellow stripes.
- C. Ground the pump, motor, and any metallic conduit that carries power cable conductors. Ground these back to the service by connecting a copper conductor from the pump, motor, and conduit to the grounding screw provided within the supply-connection box wiring compartment. This conductor must be at least as large as the circuit conductors supplying the pump.

**Save these instructions.**

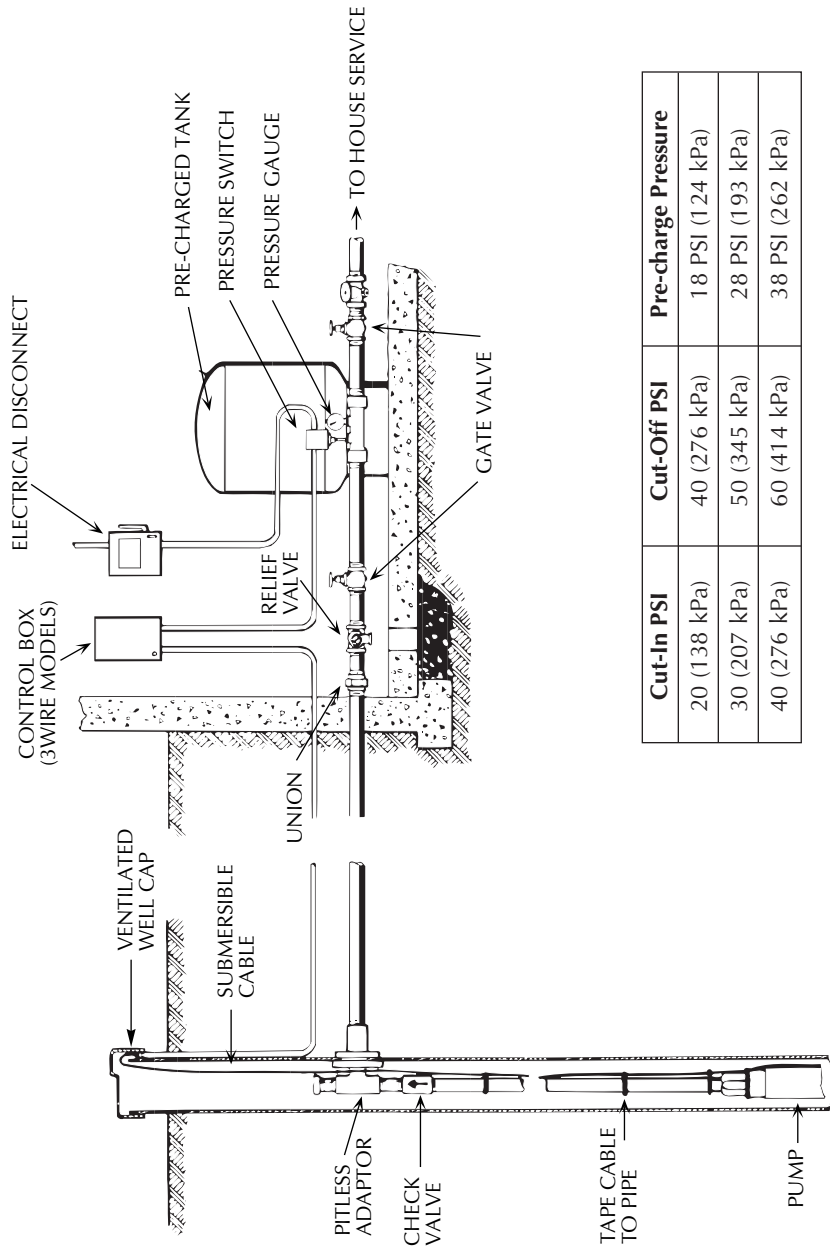

Cut-In PSI	Cut-Off PSI	Pre-charge Pressure
20 (138 kPa)	40 (276 kPa)	18 PSI (124 kPa)
30 (207 kPa)	50 (345 kPa)	28 PSI (193 kPa)
40 (276 kPa)	60 (414 kPa)	38 PSI (262 kPa)

FIGURE 14 – Typical Submersible Installation with Pre-charged Tank

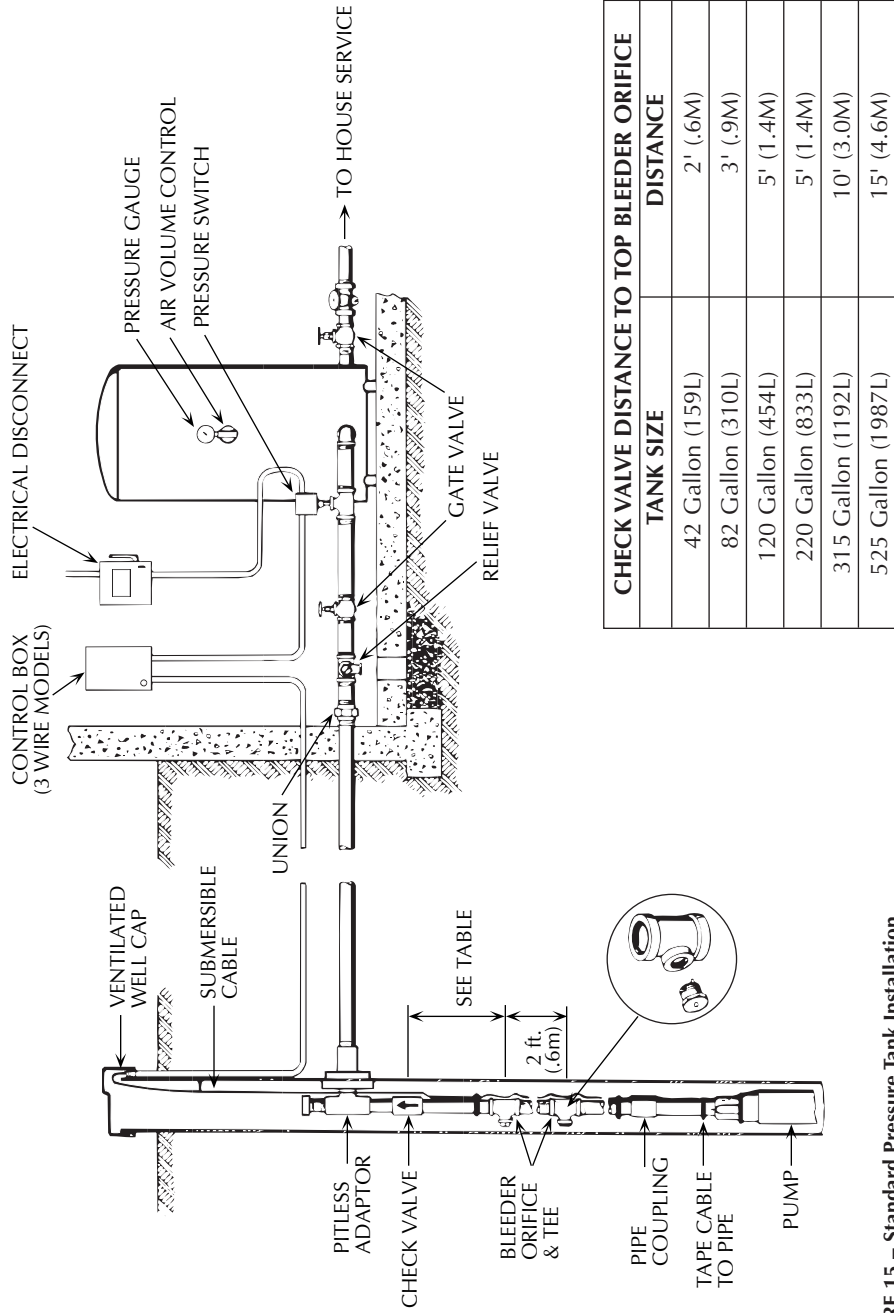

CHECK VALVE DISTANCE TO TOP BLEEDER ORIFICE	
TANK SIZE	DISTANCE
42 Gallon (159L)	2' (.6M)
82 Gallon (310L)	3' (.9M)
120 Gallon (454L)	5' (1.4M)
220 Gallon (833L)	5' (1.4M)
315 Gallon (1192L)	10' (3.0M)
525 Gallon (1987L)	15' (4.6M)

FIGURE 15 – Standard Pressure Tank Installation

## TROUBLESHOOTING GUIDE

PROBLEM	CHECK	CORRECTIVE ACTION
<p><b>Motor will not start but fuses do not blow</b> No voltage</p>	<p>No voltage at fuse box. No voltage at control box.</p> <p>No voltage at pressure switch</p> <p>No voltage on load side of pressure switch. Cable or splices bad. Control box incorrectly wired.</p>	<p>Consult power supplier, check generator. Check connections, rewire from fuse box to control box.</p> <p>Check connections, replace control box, rewire from control box to pressure switch. Check connections, replace pressure switch.</p> <p>Consult serviceman or licensed electrician. Reconnect control box correctly (see wiring diagrams, Pages 14 through 18).</p>
<p><b>Fuses blow or overload protector trips when motor starts</b> Wrong size fuse or wrong size time delay fuse. Wire size too small Starting capacitor defective or blown. Low or high voltage</p> <p>Cable leads not correctly connected to control box.</p> <p>Broken wire in control box. Pump or motor stuck or binding.</p>	<p>Check fuse size against chart, Page 4.</p> <p>Check wire size against chart, Page 5. Check control box to see if starting capacitor has blown out. Check that line voltage is within <math>\pm 10\%</math> of nameplate rated voltage while motor is running. Check control box wiring diagram against incoming power hookup. Check drop cable color coding.</p> <p>Examine all connections and wiring in control box. Check for locked rotor in pump.</p>	<p>Install correct fuse or time delay fuse.</p> <p>Install correct size wire. Replace starting capacitor.</p> <p>If voltage variation is greater than <math>\pm 10\%</math>, call power company to adjust voltage.</p> <p>Reconnect leads to match wiring diagram in control box cover. Reconnect drop cable so cable color code matches motor lead color code. Disconnect power and repair or replace faulty wire. If necessary, pull pump (make all possible above ground checks first). If pump is locked, replace it. Clean well of all sand or lime before reinstalling pump.</p>
<p><b>Fuses blow or overload protector trips when motor is running</b> Low or high voltage.</p> <p>High ambient (atmospheric temperature) Control box with wrong voltage or horsepower rating.</p> <p>Wire size too small Cable splices or motor leads grounded, shorted, or open.</p>	<p>Check that line voltage is within <math>\pm 10\%</math> of rated nameplate voltage while motor is running. Check temperature of control box.</p> <p>Compare voltage and horsepower on motor nameplate with those given on control box nameplate or on circuit diagram inside control box cover. Check wire size against chart, Page 5. Consult licensed electrician or qualified serviceman.</p>	<p>If voltage variation is more than <math>\pm 10\%</math>, call power company to adjust voltage.</p> <p>Do not mount control box in direct sunlight.</p> <p>Replace control box if numbers do not match.</p> <p>Install correct wire size. Do not attempt to disassemble pump or motor.</p>

### TROUBLESHOOTING GUIDE (cont.)

PROBLEM	CHECK	CORRECTIVE ACTION
<p><b>Pump starts too frequently</b> Leaks in system.</p> <p>Pressure switch.</p> <p>Tank waterlogged.</p> <p>Leak in drop pipe.</p> <p>Pressure switch too far from tank.</p>	<p>Check all tank connections with soapsuds for air leaks. Check plumbing for leaks.</p> <p>Check for defective switch or switch out of adjustment.</p> <p>Pre-charged tanks; check tank pre-charge air pressure, check for leak in bladder.</p> <p>Air over water tanks: check for air leaks. Check Air Volume Control (AVC). Check snifter valve operation.</p> <p>Raise drop pipe one length at a time until water stands in pipe.</p> <p>Measure distance from pressure switch to tank.</p>	<p>System must be air and water tight.</p> <p>Re-adjust or replace pressure switch.</p> <p>Pre-charge tanks: adjust air pressure to 2 PSI (13.8 kPa) less than pump cut-in pressure (when there is no water pressure on system). Replace bladder if necessary.</p> <p>Air over water tanks: repair or replace tanks; replace snifter valves if necessary.</p> <p>Replace pipe above that point.</p> <p>Move switch to within one foot (.3M) of tank.</p>
<p><b>Little or no water delivered</b> Bleeder orifice check valve stuck or installed backwards (standard tank only). Low water level.</p> <p>Low voltage.</p> <p>Plugged intake screen. Check valve at pump discharge stuck. Worn impellers and diffusers.</p>	<p>Examine valve.</p> <p>Determine lowest water level in well while pump is running and compare to pump depth setting.</p> <p>Check voltage at control box with pump running. Check incoming wire size and drop cable size against chart, Page 5.</p> <p>Pull pump and check condition of screen. Pull pump and examine check valve.</p> <p>Make sure system is clear of obstructions and pump is in solid water and operation normally.</p>	<p>If stuck, free valve; if installed backwards, reverse it.</p> <p>Lower pump further into well (but at least 5' (1.6M) above bottom of well). Throttle pump discharge until discharge equals recovery rate of well. <b>NOTICE:</b> Running pump while airlocked can cause loss of prime and seriously damage pump.</p> <p>Install larger wire from meter to control box. Install larger wire from control box to pump. If necessary, have power company raise supply voltage.</p> <p>Clean or replace as necessary.</p> <p>Free check valve.</p> <p>Replace pump.</p>
<p><b>Air or milky water discharge from faucets</b> Gas in well water.</p> <p>Air volume control not working (standard tanks only).</p>	<p>Check for presence of gas in well water.</p> <p>Make sure ports and ball check valves are clear.</p>	<p>Remove bleeder orifices; plug tees. Be sure plugged tees do not leak. If necessary, separate gas from air before it enters pressure tank.</p> <p>Replace control if necessary.</p>

## LIMITED WARRANTY

PENTAIR WATER warrants to the original consumer of the products listed below, that they will be free from defects in material and workmanship for the Warranty Period from the date of original installation or manufacture as noted.

<b>Product</b>	<b>Warranty Period</b>
Water Systems Products – jet pumps, small centrifugal pumps, submersible pumps and related accessories	<i>whichever occurs first:</i> 1 year from date of original installation, or 2 years from date of manufacture

Our warranty will not apply to any product that has been subject to negligence, misapplication, improper installation or maintenance. In the event a three phase submersible motor is operated with single phase power through a phase converter, or if three-leg ambient compensated, extra-quick trip overload relays of recommended size are not used, our warranty is void.

Buyer's only remedy and PENTAIR WATER's only duty is to repair or replace defective products (at PENTAIR WATER's choice). Buyer agrees to pay all labor and shipping charges associated with this warranty and to request warranty service through the installing dealer as soon as a problem is discovered. If warranty service is requested more than 30 days after the Warranty Period has ended, it will not be honored.

PENTAIR WATER SHALL NOT BE LIABLE FOR ANY CONSEQUENTIAL, INCIDENTAL, OR CONTINGENT DAMAGES WHATSOEVER.

THE FOREGOING WARRANTIES ARE EXCLUSIVE AND IN LIEU OF ALL OTHER EXPRESS WARRANTIES. IMPLIED WARRANTIES, INCLUDING BUT NOT LIMITED TO THE IMPLIED WARRANTIES OF MERCHANTABILITY AND FITNESS FOR A PARTICULAR PURPOSE, SHALL NOT EXTEND BEYOND THE WARRANTY PERIOD PROVIDED HEREIN.

Certain states do not permit the exclusion or limitation of incidental or consequential damages or the placing of limitations on the duration of an implied warranty, therefore, the limitations or exclusions herein may not apply. This warranty sets forth specific legal rights and obligations, however, additional rights may exist, which may vary from state to state.

Supersedes all previous publications.

**PENTAIR WATER, 293 Wright St., Delavan, WI 53115**