



# Type "B" Single Stage Centrifugal Pump Bearing Frame Mount

Section	FM
Page	260.1
Date	July 1, 2011
Supersedes 1/1/04	

## CAST IRON IMPELLERB6ZRH

### Flanged Case

### Packing Construction

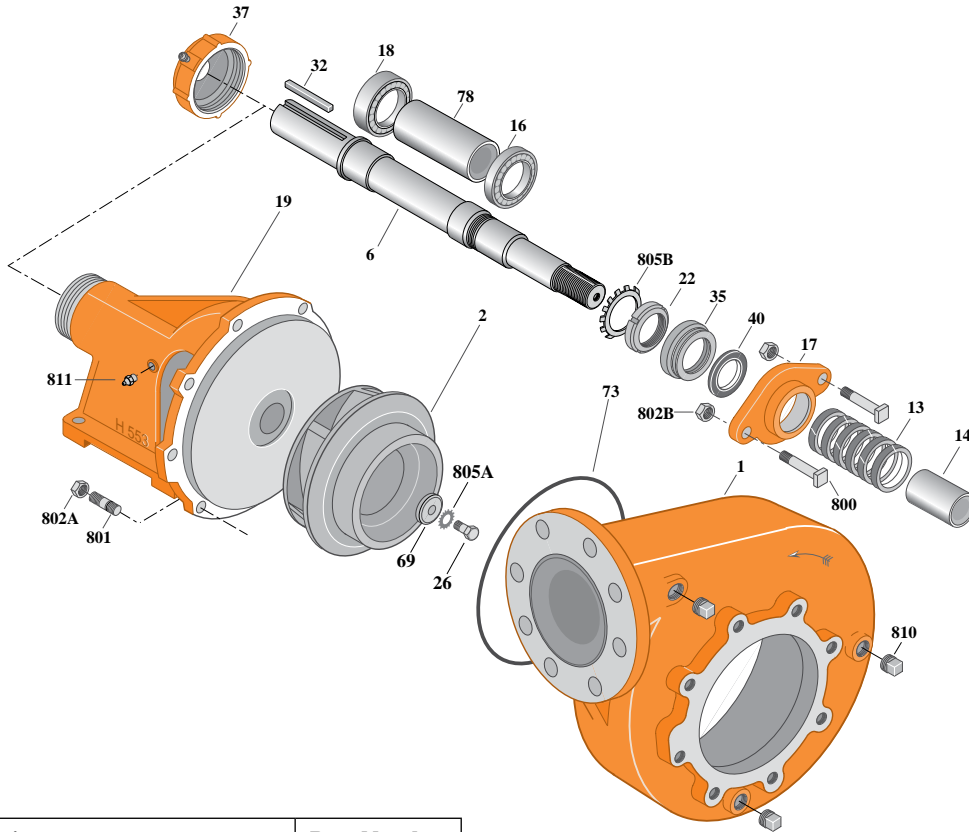

Item	Part Description	Part Number
1	Case, Volute	See Table I
2	Impeller	See Table I
6	Shaft (Not sold separately)	See Note 2
13	Ring, Packing (Set of 6)	S14022
14	Sleeve, Shaft	S05127L
16	Bearing, Ball	S13270
17	Gland, Packing (See Note 1)	S04948
18	Bearing, Ball	S13271
19	Frame	H00553
22	Locknut	M10221
26	Screw, Impeller 3/8-16x1-3/4"	S23572
32	Key, 1/4x2-1/8"	S24255
35	Inner Bearing Cap	S19033
37	Outer Bearing Cap Assembly*	S19914
40	Slinger, Water	S12260
69	Washer, Impeller	S06314
73	O-Ring (See Note 3)	M14943
78	Sleeve, Spacer	S08980

\* Includes grease fitting and set screw.

**Table I**

B/M No.	Rotation	Volute Case	Impeller	Impeller Diameter
B69501	CW	H05065	M04186	8" x 9"

Item	Part Description	Part Number
800	Bolt, Sq. Head 3/8-16x2-1/2" (2 Req.)	S23762
801	Stud, 3/8-16x1-1/4" (8 Req.)	S23994
802A	Nut, Hex 3/8-16 (8 Req.)	S23103
802B	Nut, Hex 3/8-16 (2 Req.)	S23343
805A	Washer, Lock	S23036
805B	Washer, Bearing Lock	S16181
810	Plug, Pipe 1/2 NPT (3 Req.)	S23717
811	Fitting, Grease	S23670

**NOTE 1:** A two piece (split) stainless steel packing gland is available for replacement, order part number B82468.

**NOTE 2:** Shaft Replacement Kit available for this model. Berkeley part number B07480. Pump Shaft sold in shaft replacement kit only.

**NOTE 3:** Also accepts gasket S05126 as replacement for o-ring. See **Supplement E** located at the beginning of this section.



# Type "B" Single Stage Centrifugal Pump Bearing Frame Mount

Section	FM
Page	260.3
Date	September 1, 2011
	New

## CAST IRON IMPELLERB6ZRH

### Flanged Case

### Packing Construction

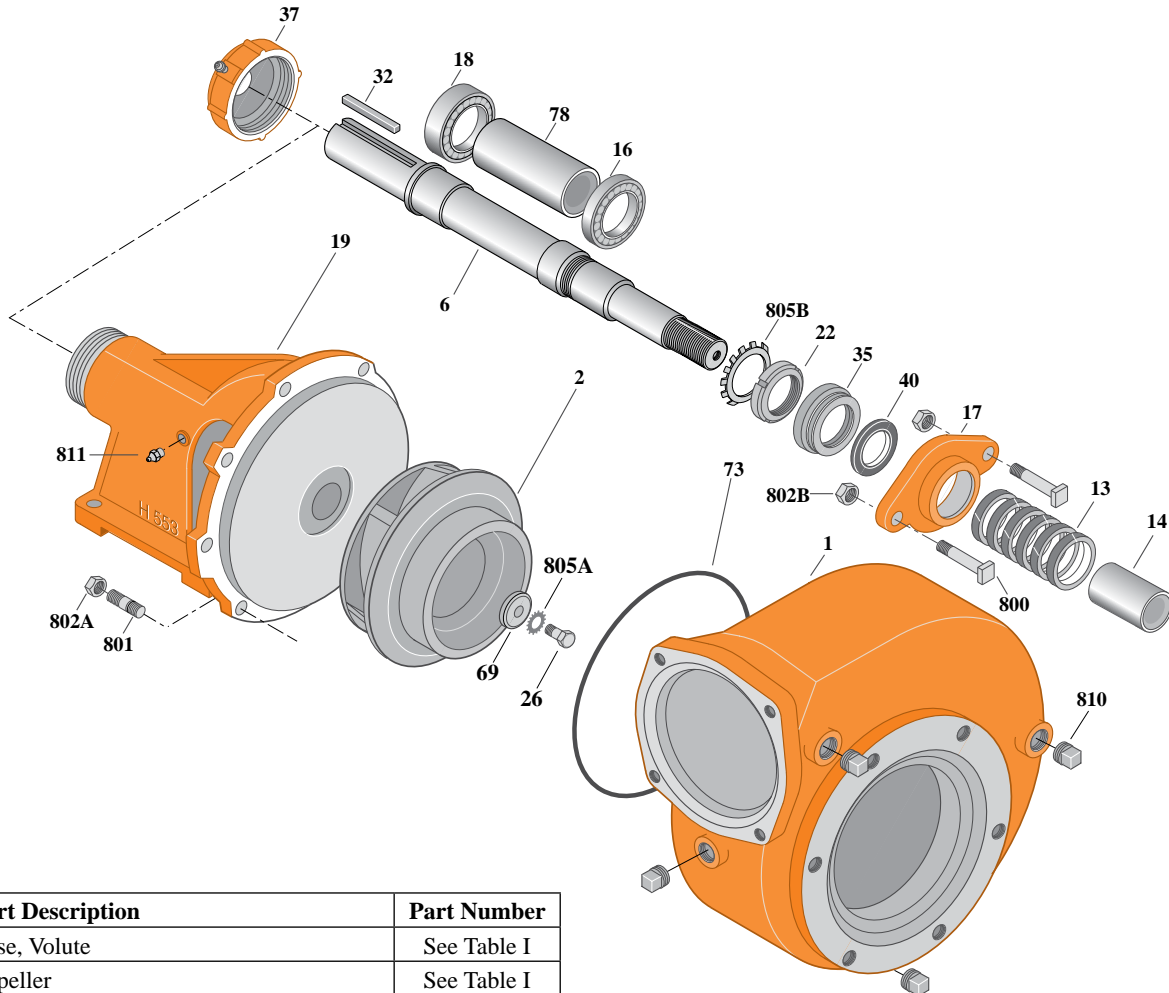

Item	Part Description	Part Number
1	Case, Volute	See Table I
2	Impeller	See Table I
6	Shaft	M03613
13	Ring, Packing (Set of 6)	S14022
14	Sleeve, Shaft	S05127L
16	Bearing, Ball	S13270
17	Gland, Packing (See Note 1)	S04948
18	Bearing, Ball	S13271
19	Frame	H00553
22	Locknut	M10221
26	Screw, Impeller 3/8-16 x 1-3/4"	S23572
32	Key, 1/4 x 2-1/8"	S24255
35	Inner Bearing Cap	S19033
37	Outer Bearing Cap Assembly*	S19914
40	Slinger, Water	S12260
69	Washer, Impeller	S06314
73	O-Ring** (See Note 2)	M14943
78	Sleeve, Spacer	S08980

\* Includes grease fitting and set screw

\*\* Replace with same as original

**Table I**

B/M No.	Rotation	Volute Case	Impeller	Impeller Diameter
B56372	CW	H01750	M04186	8" x 9"

Item	Part Description	Part Number
800	Bolt, 3/8-16 x 2-1/2" (2 Req.)	S23762
801	Stud, 3/8-16 x 1-1/4" (8 Req.)	S09942
802A	Nut, Hex 3/8-16 (8 Req.)	S23103
802B	Nut, Hex 3/8-16 (2 Req.)	S23343
805A	Washer, Lock	S23036
805B	Washer, Bearing Lock	S16181
810	Plug, Pipe 1/2 NPT (4 Req.)	U78-59ZPS
811	Fitting, Grease	M11141

**NOTE 1:** A two piece (split) stainless steel packing gland is available for replacement; order part number B82468.

**NOTE 2:** Also accepts gasket S05126 as replacement for o-ring. See **Supplement E** located at the beginning of this section.